

Gregson-Clark Eco-505-C Spray Injection System

Operator's Manual



The Eco-505-C Injection System is an add-on accessory for a turf spraying system that injects pesticide into the fertilizer stream on demand. The dual trigger spray gun and coaxial hose provide a means of minimizing unnecessary application and eliminating the need for spot spraying in a secondary operation.

Do not hesitate to call your dealer or Gregson-Clark directly with any questions or concerns. We also welcome your comments and suggestions on how we can continue to improve this product.

Toll free: 800 . 706 . 9530
Phone: 585 . 538 . 9570

Fax: 585. 538 . 9577
E-mail: Sales@GregsonClark.com



3213 Lehigh Street
Caledonia, NY 14423
www.GregsonClark.com

TABLE OF CONTENTS

Safety precautions.....	2
Overview	2
Set-Up and Assembly	3
Calibration	4
Troubleshooting.....	6
Spare Parts lists	7
Warranty.....	9

SAFETY PRECAUTIONS

Pesticides can cause personal injury and harm the environment when used improperly. Be sure to follow label recommendations concerning safety and disposal. Observe all safety precautions including wearing protective clothing and equipment.

- Calibrate and test using only water.
- Check with each use for leaks or damage.
- Always read and follow the label instructions of the products used.
- Do not exceed pressure of 90 psi on the primary (fertilizer) pumping system.
- Do not exceed 90 psi working pressure on the Eco-505-C pump system.

OVERVIEW

The Eco-505-C is an accessory device for a primary turf sprayer designed to make spot applications of pesticide while blanket applying a fertilizer solution on turf areas. The primary sprayer typically contains the material (fertilizer) to be blanket applied to the turf. The Eco-505-C contains the material (pesticide) to be spot-applied on demand.

The main components of the Eco-505-C are the five-gallon tank and pumping unit, dual line hose reel, coaxial hose, and dual trigger gun. The fertilizer solution from the primary system is pumped into the right swivel connection of the dual line reel. The pesticide solution is pumped from the Eco-505-C into the left swivel connection. Through a special hose connection assembly at the reel, the pesticide travels through the inner tube of the coaxial hose to the injection valve on the dual trigger gun. The fertilizer solution flows through the area around the inner tube, inside the main hose. Both solutions are pumped separately to the dual trigger gun.

Pulling the primary trigger of the dual trigger gun causes the fertilizer solution to spray out of the discharge nozzle. The Eco-505-C injects pesticide solution into the flow of fertilizer at the gun, just before the nozzle, by pulling the injection trigger on the gun while holding down the primary trigger.

The recommended injection rate of flow is five ounces per minute; therefore, the injection system relies on the flow of fertilizer to provide an acceptable spray pattern at a typical fertilizer application rate of 2-3 gallons per minute.

The pesticide typically is diluted with water depending on the desired application rate. The 12-volt pump provides return agitation to the tank; however, materials that require excessive agitation may not work well in the system.

SET-UP AND ASSEMBLY

Check for apparent signs of shipping damage and that the order is complete. Freight damage and shortage claims must be within five days of delivery.

Determine where to mount the tank and pumping unit on the truck. Locate it in a secure location where it is visible and easily accessible. Check under the bed for interference issues and bolt the metal frame that holds the tank to the truck bed.

If the Eco-505-C is part of a new Gregson-Clark Sprayer, the reel may have been removed for shipping purposes. Re-mount the hose reel, connect the hoses to the reel, and connect the power supply to the pump from the reel solenoid.

If the Eco-505-C is to be installed on an existing sprayer, remove the existing reel and replace it with the one provided. Make note of the wiring connections to ensure the new reel is re-wired correctly. Refer to the electrical wiring diagram for a typical system.

Connect the hose from the existing pumping system (fertilizer) to the right-hand swivel of the reel. Connect the hose from the injection system (pesticide) to the left-hand swivel of the hose reel.

WIRING DIAGRAM

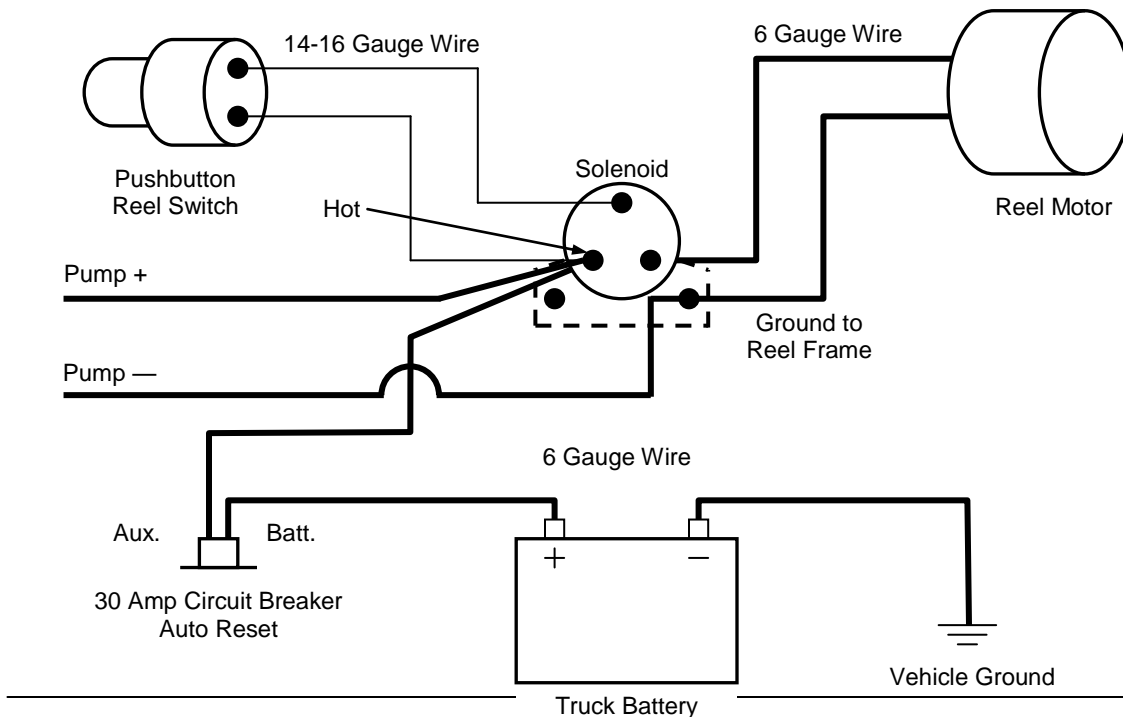

CALIBRATION

Perform a preliminary test of the Injection System with clean water and adjust the flow rate to five ounces per minute. (See Figure 1) The initial testing and calibration is done with clean water to prevent accidental spillage and waste should there be a leak. The actual chemical solution may be more viscous than water and require more pressure to achieve a flow rate of five ounces per minute.

As mentioned earlier, do not exceed 90 psi working pressure on the Eco-505-C pump system. If five ounces per minute cannot be achieved at 90 psi or below, the pesticide solution may be too viscous or there may be damage to the inner tube that carries the pesticide solution.

The primary factor affecting the application rate of pesticide will be the dilution rate of the material in the injection tank. In order to calculate the dilution rate, first determine the operator's normal application rate in square feet per minute. For normal turf spraying a typical rate is about 1,000 square feet per minute. However the walking speed and effective spray width varies between individuals so it is necessary to confirm the rate.

To determine the operator's application rate:

1. Measure an area of at least 10,000 square feet.
2. Spray the measured area with water at normal walking speed and spray width between passes.
3. Record how long it takes the operator to spray the measured area.
4. Divide the area sprayed by the elapsed time.

Example: $\frac{10,000 \text{ square feet}}{9.5 \text{ minutes}} = 1,053 \text{ square feet/minute}$

Next, determine the desired application rate of pesticide, following the label recommendations. For example, 1.2 ounces per 1000 square feet

Finally, calculate the mixing ratio using these three factors:

1. The injection system adjusted to deliver 5 ounces/minute.
2. The operator's normal application rate of 1,053 square feet/minute.
3. The desired pesticide application rate of 1.2 ounces/1000 square feet.

Use the following formula to determine how much of those five ounces is water and how much is pesticide.

Operator's Application Rate x Desired Pesticide Rate = Required Pesticide Rate/Minute

$$\frac{\text{Square Feet Applied}}{1\text{-Minute}} \times \frac{\text{Ounces}}{1,000 \text{ Square Feet}} = \frac{\text{Ounces}}{\text{Minute}}$$

Example:

$$\frac{1,053 \text{ square feet}}{1\text{-Minute}} \times \frac{1.2 \text{ Ounces}}{1,000 \text{ Square Feet}} = \frac{1.26 \text{ Ounces}}{1\text{-Minute}}$$

Therefore, of those five ounces delivered per minute, 1.26 ounces will be pesticide and the remaining 3.74 ounces will be water. Maintain this ratio when mixing the solution.

Example: 1.26 gallons of pesticide and 3.74 gallons of water will yield 5 gallons of solution.

Check the flow rate with a mixed solution in the injection tank. A solution that is heavier than water will require more pressure to achieve a flow rate of five ounces per minute. Adjust the pressure to maintain that rate while the injection trigger is on. The green ball in the flow meter should rise to near the second step, about 3/4" from the bottom, while the trigger is pulled. (See figure 1)

The flow meter is slow to respond to pressure changes. Wait 10-15 seconds while the trigger is depressed to get an accurate reading. Observe and record the pressure gauge and flow meter readings. These readings should remain constant as long as this solution is used.

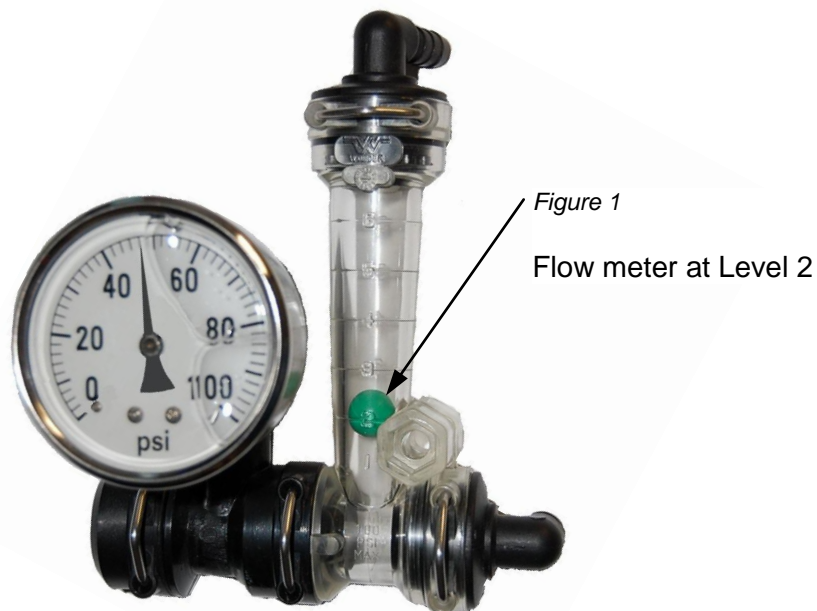

TROUBLESHOOTING

Problem	Possible cause	Solution
Pump does not run	Open electrical circuit	Check truck's battery charge Check for power to the pump Check ground to frame Check for open circuit breaker
	Defective pump	Replace as necessary
Pump runs slowly	Low voltage to pump	Check truck's battery charge
Low pressure and low flow	Pump has lost prime	Re-prime the pump by backing the Pressure Regulator all the way out
	Inadequate flow of liquid to the pump	Check liquid level in tank Clean strainer Tighten strainer bowl Check bowl gasket Check pressure gauge reading Ensure the shut-off valve is open
	Plugged pressure regulator	Disassemble and clean
	Debris in pump	Repair as necessary
	Check valve stuck open	Repair as necessary
	Solution in tank too viscous	Dilute if necessary or change materials
	Defective pump	Repair as necessary
Pressure adequate but low flow	Restriction in spray gun	Inspect and clean as required
	Restriction in hose reel	Disconnect and flush hose

Table 1

SPARE PARTS LIST

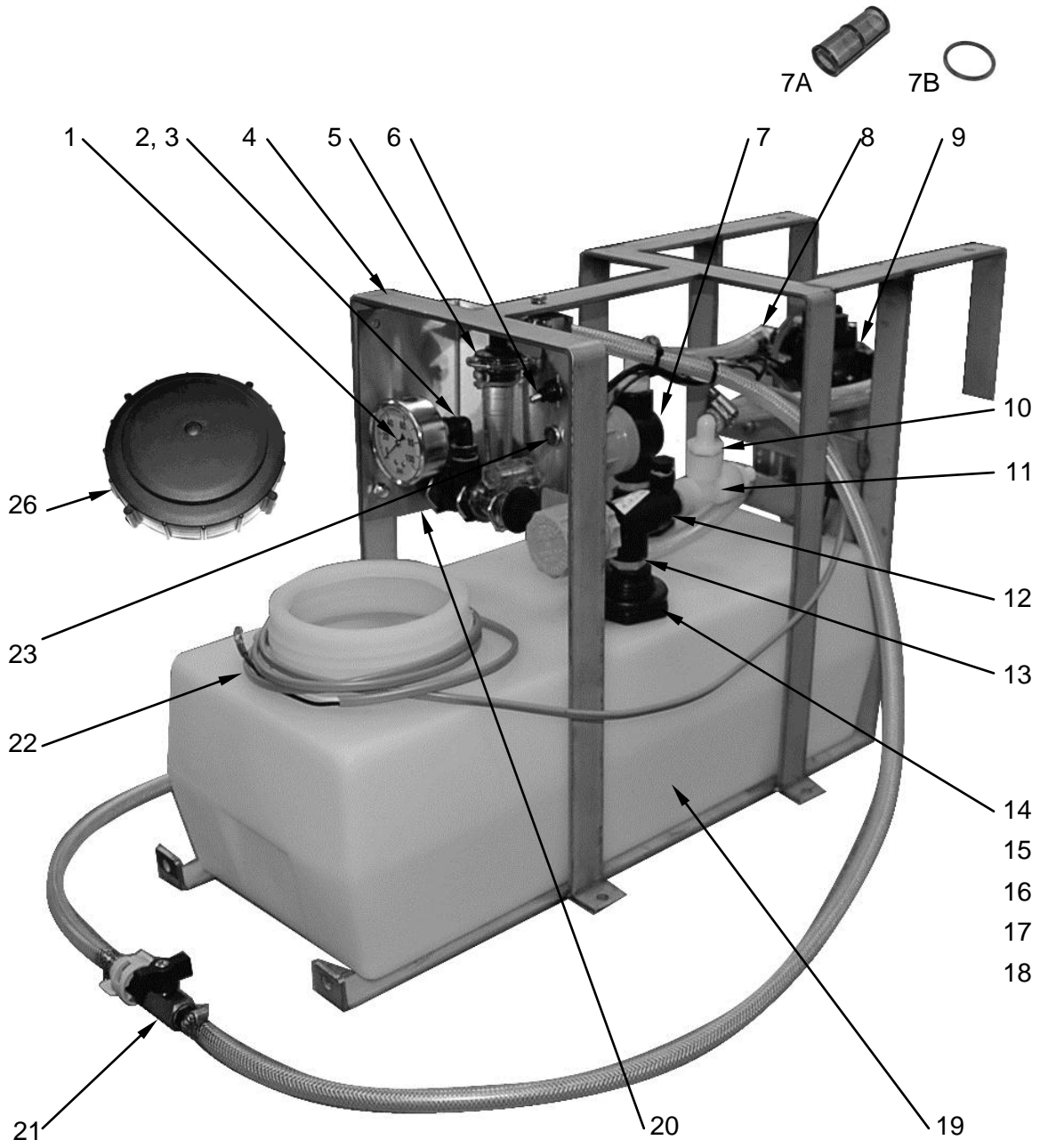

REF. #	QTY.	PART #	DESCRIPTION
1	1	2141GXB100	Pressure Gauge 0-100 SS Liquid Filled
2	1	SE14P	Street Elbow 1/4" Poly
3	1	RB3814P	Bushing 3/8" x 1/4" Poly
4	1	Eco-505-C Frame	Compact Eco Frame
5	1	20460-ECO-SG	Flow Meter Assembly
	1	20460-00	Flow Indicator Assembly
	2	20511-00	O-ring fitting x 3/8" Hose, 90 Deg
	1	20521-00	End Cap w/ U-clip
	1	20524-00	Inline Gauge Port
	1	RB3814P	Bushing 3/8" x 1/4" Poly
	1	SE14P	Street Elbow. 1/4" Poly
6	1	44280	Toggle Switch, Weatherproof
7	1	AA122-1/2-PP50	Strainer 1/2" 50 Mesh (Complete Assembly)
7A	1	CP45102-3-SSPP	Strainer Screen 50 Mesh
7B	1	CP23173 EPR	Strainer Bowl Gasket
8	2	234-3926	Barb Elbow Swivel 1/2" FPT x 1/2"
9	1	8000-543-138	Shurflo Pump 1.8 GPM
10	2	EL1238	1/2" MPT x 1/2" Hose Barb
11	1	TT12	Tee 1/2" FTP
12	1	23120-1/2-PP	Pressure Regulator
13	2	M12	Close Nipple 1/2"
14	2	TF050	Tank Fitting, 1/2"
15	2	A12	1/2" MPT x 1/2" Hose Barb (Inside Tank)
16	1	A1412	1/4" MPT x 1/2" Hose Barb (Inside Tank)
17	1	TT14	Tee 1/4" MPT (Inside Tank)
18	2	EL14	Hose Barb 90 deg – 1/4" (Inside Tank)
19	1	SP0005-RT	Poly Tank, 5 Gallon
20	1	EC2105	Meter Mounting Bracket
21	1	EC1152-SG	Check Valve Assembly
	1	QJ1/4T	QJ Body 1/4 FTP
	1	CP19438-EPR	Seat Washer
	1	CP25607-6-NY	QT Cap NY Yellow
	1	8400-406-NYB	Hose Shank 3/8"
	1	A1438	1/4" MPT x 3/8" Hose Barb
	1	11750-5	Check Valve Tip, Brass
	1	MVT14FM	Valve, 1/4" FPT x 1/4" MPT
22	1	62145	Wire, Duplex 14/2
23	1	73425G	Indicator Lamp, Green
24	1	EC2106	Cover (Not Shown)
25	1	EC2107	Front Shield (Not Shown)
26	1	10522	Tank Lid Female 5" With Vent

WARRANTY

The Gregson-Clark Eco-505-C is warranted by the manufacturer to the original purchaser to be free from defects in materials and workmanship for a period of one year. The pump elastomers are considered normal wear items and carry a 90-day warranty against defects in materials and workmanship.

Gregson-Clark's liability shall be limited to replacement of defective components, FOB shipping point. In no event shall Gregson-Clark be liable for any special, incidental, or consequential damages including loss of profits.