

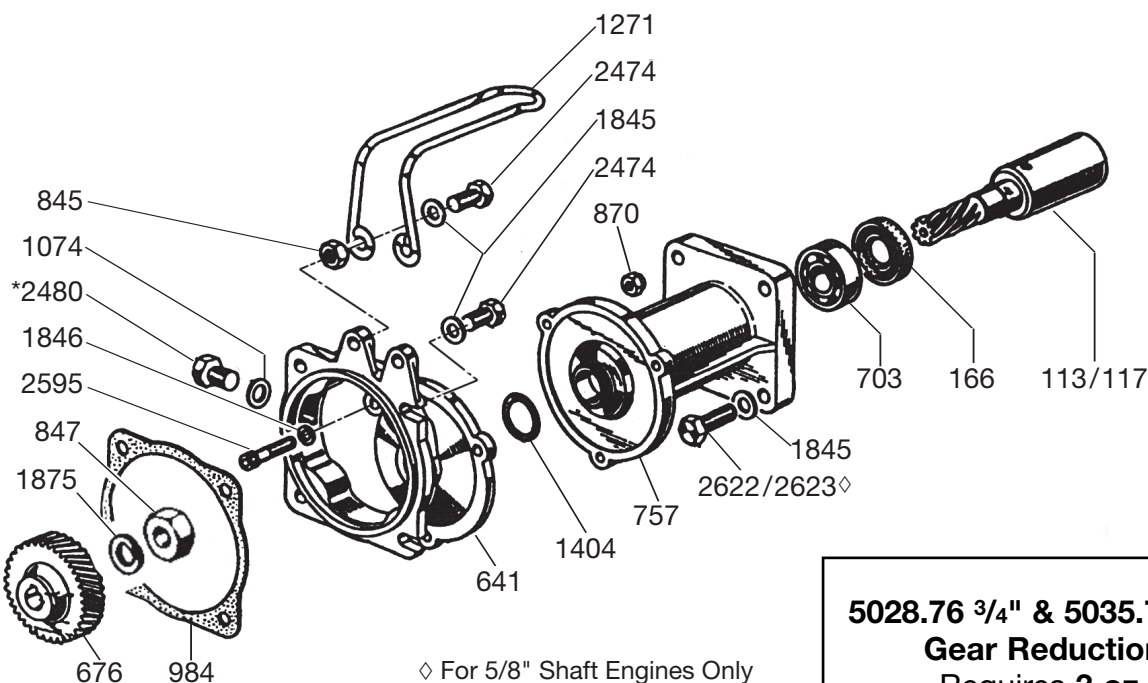

# 5028.76 & 5035.74 Gear Reduction

## Installation Instructions for IOTA-17/GR



**5028.76 3/4" & 5035.74 5/8"**  
**Gear Reduction**  
 Requires **3 oz.**  
**90W** Gear Lube

REF#	PART#	DESCRIPTION	QTY	REF#	PART#	DESCRIPTION	QTY
113	0004.19	Engine Gear, 3/4"	1	1074	0605.41	Gasket	1
117	0004.24	Engine Gear, 5/8"	1	1271	0902.19	Handle	1
166	0007.21	Seal	1	1404	1101.61	O-Ring	1
641	0210.25	Gear Case	1	1845	1403.10	Washer	8
676	0213.13	Pump Gear	1	1846	1403.07	Washer	1
703	0214.08	Bearing	1	1875	1404.01	Washer	1
757	0228.24	Mounting Flange	1	2474	1804.57	Bolt	6
845	0303.01	Nut	2	2480	1804.76	Oil Level Plug	1
847	0303.10	Nut	1	2595	1805.19	Bolt	3
870	0304.02	Nut	3	2622	1807.07	Bolt - 5/16" x 1"	4
984	0602.25	Gasket	1	◇2623	1804.63	Bolt - 8mm x 1.25	4

**NOTE - USE BLUE THREADLOCKER OR EQUIVALENT ON ALL BOLTS.**

- Before installing assembly onto engine, remove oil level plug (Ref. #2480) and add 3 oz. of 90 W gear lube to gear box.
- Apply a light coating of anti-seize compound or grease to engine shaft and install 3/16" key, which is provided with the engine. Slide assembly over engine shaft and fasten to engine using (4) 5/16" x 1" bolts (Ref. #2622) and (4) washers (Ref #1845) provided.

5028.76 & 5035.74